



2024 Touring Rules and Regulations

1. General Rules

1A. Rule Book Disclaimer: Rules and/or regulations set forth herein are designed to provide for the orderly conduct of racing events and to establish minimum acceptable requirements for such events. These rules shall govern all events, and by participating in these events, all participants are deemed to have complied with these rules. **NO EXPRESSED OR IMPLIED WARRANTY OF SAFETY SHALL RESULT FROM PUBLICATIONS OF OR COMPLIANCE WITH THESE RULES and REGULATIONS.** They are a guide and are in no way a guarantee against injury or death to a participant, spectator, or official. American Crate All-Star Series dba American All-Star Series, known throughout the rules as ACAS, retains the right to make all decisions and reserves the right to make any rule changes/amendments without dispute or appeal for the betterment of the ACAS. The ACAS reserves the right to refuse business to anyone at any time.

1B. Appeal Process: By participating in ACAS sanctioned events, drivers forego any right to file any appeal.

1C. Series Membership Fee: \$100 Annually or can be paid in \$25 increments in four consecutive races

1D. Entry Fee: \$110 Per Race plus \$10 for transponder rental/\$5 scoring fee if you have your own transponder. Any event paying \$11,000 to win or more will have a different entry fee as set per the event.

1E. Point System: 50, 48, 46, 44, 42, 40, 38, 36, 34, 32, 30, 28, 26, 24, 22, 20, 18, 16, 15, 14, 13, 12, 11, 10 (This will be a standard 24 car field.) From there in the B-main, points will continue for non-transfer cars as follows: 9, 8, 7, 6, 5, 4, 3, 2, 1. (Any remaining cars will receive 1 point.) Only those who pay the \$100 membership fee will earn points. However, those who pay the \$25 temporary membership increments will earn points from the point they start paying and at each event they continue to pay. 50 show-up points will be awarded to members at each event on top of the points earned.

1E1. Hardship Points: Once per season a member can earn 50 hardship points. As long as a call is made to the series in advance of the event a driver can miss an event with no questions asked and be awarded 50 points. Hardship points events will not count toward the 80% or 50-79.99% attendance rule, nor will it allow you to keep the perfect attendance tow money bonus.

1E2. Bonus Races: Bonus races do not count against the racer as far as any attendance bonuses are concerned but will count to help racers who attend with their percentage

of races attended. Bonus races will also count to replace a driver's lowest points night(s). If a driver has a lower points night or a missed race, the bonus race finishing points will be used to replace those finishes. Bonus races will not be calculated into the points until the final race of the season is complete.

1F. Tow Money: Members with perfect attendance after the third (non-bonus) event is held will be eligible for tow money IF they travel more than 250 miles from their home to the race. A GPS will be used to the driver's home address to determine if the driver is eligible for the bonus. The bonus will be \$100 for a one race weekend. On multi-race weekends if both events are 250 miles or more from the driver's home address the racer will receive \$50 at the second show and on a three-day weekend a third amount of \$50 will be awarded at the third show. **THIS IS ONLY FOR MEMBERS WITH PERFECT ATTENDANCE.** Bonus races will not count against this if you do not attend, but tow money will be awarded for those attending bonus races.

1G. Awards Banquet: Drivers/car owners are expected to attend or have a representative attend. If a driver does not send someone to the banquet, he will forfeit all awards/monies. In the event of a tie for any championship, a tiebreaker will be determined by the driver with the most wins, then 2nd place finishes, etc. If a tie happens in any other position, the same procedure will be followed. The top 10 drivers will be paid for points as long as they have competed in 80% of the races. Drivers who attend 50%-79.99% of the touring events that are members will receive 50% of the posted points money amount. Any driver from 11th back that is a member will receive \$500 for points if they have completed 80% of the races.

1G1. Rookie of the Year: To be eligible to run for Rookie of the Year you must have never run for points with any other crate (or higher class of competition) series.

1G2. Engine Seals Bonus: If your engine is sealed with AAS Series Seals or you have proof of purchase from Rick Hendrick City Chevrolet and have GM seals, you will receive a 20% boost to points money. *Must be run the whole season.

1H. By racing with the AAS, you understand and agree that the series may use your name, image, and/or likeness for marketing purposes including on social media, websites, and merchandise sold.

1I. Any illegal car or cars will not receive money and points and will be subject to suspension, fine, probation, or all three. The ACAS makes the final decision if a car is illegal, and there is NO appeal process. The ACAS reserves the right to adjust the severity of any suspension, fine, or probation at any time. The ACAS may inspect any part of any car at any time, and by racing with the series you agree to abide with all findings legal or illegal. By racing with the series, you forfeit any right to appeal.

2. Event Procedures:

2A. Unacceptable Behavior:

2A1. Fighting or drinking at the event by any driver or crew member will NEVER be permitted. Automatic disqualification will occur on the night of the event; further suspension or permanent expulsion from the series may result as well.

- 2A2. If a driver or crew member enters another's pit area, that team will be considered the aggressor in the situation and will be subject to the harshest of punishments. DRIVERS are responsible for all their team members.
- 2A3. Random drug testing may be done at any time. Failure of the drug test or to accept the drug test will result in suspension and possibly a fine.
- 2A4. Poor sportsmanship may also result in suspension or fine. Any poor sportsmanship on the track or roughness will result in the removal of the driver performing the act and disqualification for the night.
- 2A5. Refusal to obey officials could result in suspension, fine, probation, or all three. This includes yelling at or disrespecting any series or track officials either at the track or on social media. Social media remarks can extend from driver to anyone associated with the team.
- 2A6. If a driver gets out on the track for any reason other than safety, he or she will be disqualified. If a driver's crew goes on the track, the driver will be disqualified.
- 2A7. Driving in the pit area must be done at a reasonable pit road speed (Courtesy laps will not start until the driver is in his/her pit area.). Drivers will be subject to penalty for driving too fast.
- 2A8. If a driver intentionally hits another driver's car under caution, hot laps, or in the pits, that driver must pay a \$100 fine (could vary based on the severity of the damage) to the driver he/she hit at that time. This fine must be paid in order to compete with ACAS again.

2B. Pre-Race: All drivers are expected to sign in before the race and attend the driver's meeting.

- 2B1. Any driver not attending the drivers' meeting will only receive the first lap of his/her qualifying session.
- 2B2. Drivers must all sign in under their correct names. If a driver finishing the race does not match the signed in name for that car, the driver and car will be disqualified. Official driver changes are allowed if communicated to series officials prior to the change; however, an official driver change will result in the driver starting the tail. **A driver change can include a driver switching cars or a car owner putting a different driver in his/her car. A driver may change engines in extraordinary circumstances, but if this were to occur (and that driver was already locked into the feature) the driver must start on the tail of the feature event.**
- 2B3. All cars must complete pre-race tech. **If a driver switches cars, the car must pass tech before entering the speedway.**

2C. Flags: The flag meanings are as follows:

- (1) Green - Start the race.
- (2) Yellow - Everyone slow to a safe speed and follow the car in front. Lineups will put all lapped cars to the tail (including behind any lead lap cars who pitted).
- (3) Red - Danger is on the speedway. Stop as quickly as possible.
- (4) Black - Pull into the pits.
- (5) Blue with Yellow Stripe - The car is about to be lapped. "Hold your line."
- (6) White - One lap to go.
- (7) Checkered Flag - The race is over, slow down.

2D. The Race: All drivers will compete in optional hot lap sessions, qualifying sessions, dash/heat races, B-mains (if necessary), and features.

2D1. All cars are expected to participate in qualifying. There will be a fast six dash based on the qualifying results. These six drivers will be locked into the top three starting rows of the feature. The dash will be six laps for six racers. The rest of the cars will be lined up in heat races based on qualifying. 33 cars or less will result in one group of qualifying. 34-59 cars will have qualifying split into two groups. 60 or more cars will have three groups. If there are two groups of qualifying three from each group will go to the dash and if there are three groups of qualifying two from each group will go to the dash. Special non-points and \$15,000 to win or more events may have a different qualifying format. There will be provisional positions held for 23rd and 24th for participating members of the series only. The first three races (not including bonus races) of 2023 will use provisionals for 2023 members based on 2022 points.

2D2. On initial starts of the event the pole sitter will start the race between the apex of 3 and 4 and the second start box flag and the leader will set the pace coming to green. It MUST be a consistent pace. Firing before the green flag will result in a jumpstart warning. If it happens again, the driver will be put to the tail and charged with a caution. If a caution occurs before the first lap is completed, everyone will get their spot back (who did not go to the pits), and the race will start again.

2D3. Restarts will be Delaware Double-File through the whole show until the last 5 laps of the feature. The leader will be out front by himself, and the second-place driver will choose inside or outside. From there drivers will be lined up based on what the second-place driver chose. The leader will start the race between turns 3 and 4 in the marked start box. If the leader has not fired by the exit of the start-box, the other drivers may go. If a driver fires before the leader, he/she will be charged with a jumpstart where the same rules apply as on the initial start. If the series deems the track has moved to one groove it reserves the right to make restarts single file.

2D4. Drivers will be given a total of 2 cautions per event or 3 individual cautions per race night. If two are used in the heat, the driver will be pulled to save the final caution for the b-main or feature.

2E. Cautions: The series will enforce a modified no stop rule in the event of a caution. The car who originally stopped and any other car stopping and making contact will go to the tail. If a caution comes out because a car is spinning in front of the field, even if the car doesn't stop, that driver will go to the tail. Cars stopping to avoid after the initial wreck has occurred, that make no contact, will get their spots back. If it is deemed someone intentionally wrecks another driver that driver will be parked.

2E1. The driver(s) who stopped in the incident will go to the tail of the field (or lead lap cars if also a lead lap car) on the restart. Everyone else will get their position back, if they do not enter the pit area.

2E2. Series officials will pull sheet metal if it can be done in a reasonable amount of time (30 seconds).

2E3. Drivers in the B-mains and features will be given two laps to go pit-side and change a flat tire or pull sheet metal under a caution.

2E4. If an accident occurs coming to the checkered flag off turn four, the same rules apply as the no stop rule. If the checkered flag flies instead of a yellow, cars involved in the accident will be frozen in their positions from the last lap except for the

driver(s) who stopped in the initial accident. The driver(s) at fault will finish as the last car on his lap. If AT ALL POSSIBLE, the yellow flag would wave here instead of a checkered flag.

2E5. Any car that is charged with a caution two times in the feature event will be put off the track. (As long as the black flag is obeyed at this time, the driver will be paid and scored in the position he leaves the track.)

2E6. Any car that goes to the pits for any reason must restart the race on the tail of the field. (The car will be put in front of lap down cars if it is a lead lap car.)

2F. *Winning the Race:* The last green flag lap must be completed to be the leader of the race. A green flag lap is considered completed if half the field (rounded down when an uneven number of cars) has crossed the start/finish line when a caution flies. On the final lap of the event, if an accident occurs, racers will race to the checkered flag IF all cars have taken the white flag and IF it is deemed safe by the series officials. (Example: If the accident occurs on the front stretch right after the finish line, a caution will be called for safety purposes.)

2G. *Payout:* Tracks are responsible for paying the series the agreed upon payout.

2G1. The series will pay the drivers at the end of the night once the track has paid the series. The track may pay out if they so choose, and a series official will act as a witness when paying drivers of the series.

2G2. All cars that start the feature event will be paid for starting if they are not disqualified from the event.

2G3. Payouts will be held from drivers who have tire samples taken, an engine protested, or any other post-race tech item that requires a waiting period. When test results are returned and if they are in the driver's favor, the driver will be paid.

2H. *Rainouts:* We understand every rainout situation will be unique, but generally these rules will apply:

2H1. The series will hold entry fees for the makeup event; if no makeup event is scheduled the entry fee can be used at any race in the next 365 days from the date of rainout.

2H2. All preliminary events through the B-Mains must be completed for a makeup feature only to be scheduled (if possible); otherwise, we will restart the show unless event is held over until next day at which point, we will complete the started show.

2I. *Post-Race Tech:* Drivers need to be prepared for tire samples, fuel tests, and to remove a valve cover, 2 rocker arms and all spark plugs for post-race engine tech. Tech Directors will be performing a cam check, compression check, valve spring test and P&G post-race. Tech Directors will also spot check using a bore scope to look inside intake manifold and in cylinder. Tech director may take a valve spring sample from the winner, 2nd, and/or 3rd place cars after each race. Drivers who have a valve spring sample taken will be given one by the series as a replacement. If the sample comes back good the valve spring will also be returned to the driver. All cars are expected to roll through the scales following qualifying, top 3 after the dash/heats, all transfer cars plus 1 after the B-Main, and the top 5 after the feature. *Head Technical Inspector reserves the right to determine all post-race tech inspections. Decisions are his alone and final. **Crews are expected to have tools ready at tech.**

3. Technical Rules:

3A. Engines: GM part number 19258602 or 88958602 and GM part number 19318604 or 88958604 are the only engines that will be permitted to participate in the series.

- 3A1. All engines and parts must be as from factory and all components thereof. All engines are to remain sealed from the factory. These engines are sealed at the intake manifold, cylinder heads, front cover, and oil pan with special GM twist-off bolts or with the cup style seals.
- 3A2. Any “unauthorized” changes will result in disqualification, no points, fines, and other possible penalties including, but not limited to, being barred from ACAS sanctioned competition. This includes, but is not limited to, harmonic balancers, valve springs, push rods, rocker arms, aftermarket valve covers etc. Tampering, removal, or modifications of any type and/or broken, tampered factory seals will not be permitted and will result in immediate disqualification from the event. The engine may be impounded immediately for further inspection.
- 3A3. The only exception will be if a repair or rebuild is required. The repair/rebuild must be authorized by the American Crate All-Star Series, at which time the engine may be repaired or possibly rebuilt per the guidelines set forth in the GM Technical Manual #88958668 or any subsequent revision of this manual. Crate engines must not be altered, modified, or changed from factory specs.
- 3A4. Engines **MUST** be sealed in all of the above stated locations with either the **original** New GM seals, ACAS (say All-Stars) Seals (Blue), FASTRAK seals, SECA seals, or Nesmith Crate racing gen IV (green), gen V (black), seal tags, RUSH and UCRA std. Any other series seal that allows no changes within the bolts may be considered legal. (No RM, UCRA .020, counterfeit or eBay bolts will be allowed.) The ACAS reserves the right to tear down any engine following any event at car owners’ expense. **Any parts found illegal will be kept and destroyed by the series.**
- 3A4a. Old style GM Twist bolts or Crate Racing Gen III (yellow) bolts may be run, but if they finish in the top three of feature event, they will be torn down at the driver’s expense.
- 3A4b. Though other series seals are accepted in the instance of an engine dyno and/or teardown all engines will be inspected to meet the rules set forth in the GM Performance Circle Track Crate Engine Technical Manual and in the ACAS Rulebook.
- 3A4c. ACAS reserves the right to confiscate any GM parts to be sent to the manufacturer at any time.
- 3A5c. Competitors choosing to run AAS seals or who have a stock GM motor with proof of purchase from Rick Hendrick City Chevrolet will receive a 20% bonus in points money. There may be other events where a bonus will be added.**
- 3A5. The sealed engines must remain intact and not be tampered with; any seals that have been tampered with, removed, modified, and/or broken will make the engine illegal and result in immediate disqualification from the event (loss of points and money). The engine may be impounded immediately for further inspection. Modifying any internal engine parts or changing the parts from stock as delivered sealed from the factory will result in disqualification for the night’s event (loss of points and money).
- 3A6. The permitted GM factory sealed crate engines must not be altered, modified, or changed from the GM specifications in the GM Technical Manual #88958668 or any subsequent revision of this manual; no changes at all are allowed to the engine -

intake, manifold, valve covers, heads, front cover, oil pan, harmonic balancer, or any other part or parts on or in the engine.

3A7. We will allow Clevite P series rod, main and cam bearings. Aftermarket valve cover gaskets and breathers will be allowed.

3A8. Engine Setback: 25 ½ inches (measured from center of ball joint to front of engine plate).

3A9. *Engine Protest Rules:*

3A9a. Top 5 main event finishers may protest any Top 5 finisher in front of them.

The protested driver may counter protest within 5 minutes of being notified of protest. All protests must be made to ACAS officials by the driver. Driver must have cash in hand. Claim fee must be paid within 5 minutes of protested car crossing scales.

3A9b. Engine Claim Rule: Drivers may claim another's GM 604 for \$8,200.

When claiming an engine, the driver will only receive it as delivered from GM with no accessories, distributor, wires, carburetor, pumps etc. Engines must be available from GM for a claim to be allowed.

3A9c. Engine Dyno Protest Rules: The protest fee is \$1,200. The winner of the protest receives \$600. The engine dyno shop will receive \$400 and the series will receive \$200. The only engine dyno shop used for a dyno protest will be: Pro-Built Race Engines in Sevierville, TN. The series will have a stock set of headers and carb on hand, as well as, a series engine to compare to the suspect engine. If the engine does not dyno within the set series numbers, it will be considered illegal. If the engine is found illegal, the protester will receive their money back, and the protested driver will have to pay the \$1,200 fee to get the protested engine back. In the case of a full engine protest, the series representative will claim the entire engine and meet at a selected technical inspector's business at the appointed inspection time. Series may decide to pull any engine for dyno at any time at the owners expense. If an engine dynos out of the appointed specs the driver may pay \$1,000 to have his/her motor torn down. If the motor is the found correct the driver will receive the \$1,000 back. This MUST be paid in cash. If a driver is found to be cheating a \$3,000 fine will be levied on the driver, and the driver will be banned from any ACAS competition for 365 days. The \$3,000 fine will be paid in addition to the \$1,200 fee to get the engine back, both fees must be paid before the engine is returned. Suspension may be levied against the driver and/or car owner. Failure for a representative to show up at the appointed dyno time is an automatic disqualification. Failure for a protesting competitor to attend the dyno, will result in the protesting driver forfeiting the dyno.

3A9d. Complete Engine Protest Rule: The protest fee is \$2,000. The winner of the protest receives \$1,700, the series receives \$100, and the ACAS selected technical inspector receives \$200. If the engine is found illegal, the protester will receive their money back, and the protested driver will have to pay the \$2,000 fee to get the protested engine back. In the case of a full engine protest, the series representative will claim the entire engine and meet at a selected technical inspector's business at the appointed inspection time. Illegal parts will not be returned. If a driver is found to be cheating a \$3,000 fine will be levied on the driver, and the driver will be banned from any ACAS

competition for 365 days. The \$3,000 fine will be paid in addition to the \$2,000 fee to get the engine back, both fees must be paid before the engine is returned. A refusal to accept tear down is an admission to guilt and subject to a two-year, \$3,000 fine. Suspension may be levied against the driver and/or car owner. Failure for a representative to show up at the appointed dyno time is an automatic disqualification. Failure for a protesting competitor to attend the dyno, will result in the protesting driver forfeiting the dyno.

3A10. Engine Head Flow: The ACAS may flow an engine head at any time to compare it to the series stock GM head. The CFM of confiscated head(s) cannot flow more than 5 CFM better than the ACAS head.

3A11. Engine Head Tech: Engine head cannot be altered in any way from stock. The series will have a sample head for comparison. Suspect head may be compared to samples head (separate from the flow rule, which does not apply to this rule). If technical inspector determines the head has been tampered with the motor will be deemed illegal.

3A12. Intake Manifold Tech: Suspect intake manifold will be compared to series intake manifold for inspection. Measurements and weight may be checked when inspecting the intake manifold.

3A13. Valve Spring Specifications: **No PAC Springs**

3A11a. Valve Spring Protest: Protesting of the Valve Spring is \$200 and must follow the same procedures as protesting an engine. ACAS will provide protested driver with a Valve Spring. If found legal, legal valve spring will also be returned to the driver. Please see rule 3A9.

3A12b. (Valve Spring Penalties based on 365-day period from time of infraction.)
1st Offense: \$200.00 fine, loss of points, loss of prize money, and 25-point deduction to year end points total.

2nd Offense: \$350.00 fine, loss of points, loss of prize money, and 50-point deduction to year end points total.

3rd Offense: \$500.00 fine, loss of points, loss of prize money, and suspension to be set at ACAS discretion.

| Valve Spring Specifications – Old (non-beehive) | | | | |
|---|-----|----------|----------|----------|
| Description | | 88958602 | 88958603 | 88958604 |
| Valve Spring P/N | | 10212811 | 12551483 | 12551483 |
| Valve Spring P/N -set of 16 | | n/a | 12495494 | 12495494 |
| Diameter (+/- .010") | (A) | 1.250" | 1.340" | 1.340" |
| Free Height (+/- .015") | (B) | 2.021" | 2.154" | 2.154" |
| Installed Height (Ok to shim to proper height) | (C) | 1.70" | 1.780" | 1.780" |
| Pressure @ Installed Height (+/- 5 lbs) | (D) | 80 lbs. | 110 lbs. | 110 lbs. |
| Open Height | (E) | 1.270" | 1.300" | 1.300" |
| Open Pressure (+/- 10 lbs) | (F) | 195 lbs | 270 lbs. | 270 lbs. |
| Coil Bind | (G) | 1.20" | 1.21" | 1.21" |

| | | | | |
|---------------|--|-------|-------|-------|
| Wire Diameter | | .177" | .178" | .178" |
|---------------|--|-------|-------|-------|

Blue Beehive Valve Springs:

| Valve Spring Specifications – New (Blue) Beehive Valve Spring | | |
|---|--------|-----------------|
| Description | Engine | |
| CT 400 Engine | | 88869604 |
| Valve Spring P/N -16 | | 12499224 |
| Valve Spring P/N | | 12625033 |
| Diameter Top (+/- .010") | | 1.060" |
| Diameter Bottom (+/- .010") | | 1.270" |
| Free Height (+/- .015") | | 2.122" |
| Max solid height | | 1.210 |
| Min Installed Height (Ok to shim to proper height) | | 1.780" |
| Pressure at installed ht (+ 5 lbs tolerance) | | 98lbs |
| Open Pressure (+/- 13 lbs) | | 267 lbs. |
| Wire diameter (Ovate) | | (.168" x .211") |
| Retainer. 19303149 | | 11.9g |
| Keeper. 19302868 | | 3.9g |

3B. Weight: GM 602 Car and Driver (2200) and GM 604 Car and Driver (2300).

3B1. The top 5 cars will weigh after each feature before going to victory lane or the trailer. If a driver chooses to weigh outside the top 5 and is light, he will be disqualified. Drivers will be given two attempts at weighing correctly following the event. In the process the driver will be pushed either forward or backwards (whichever is applicable in the situation), and scales will be reset, and car will be pushed back on the scales. After the second attempt if the car is still light the car will be disqualified. Tracks scales will be used, and everyone will be weighed to the same standard by their scales. Weights listed are the weights expected following the event. There will be no burn off given unless otherwise stated prior to the event.

3B2. After qualifying every car must cross the scales. The top three must cross after the heat. All transfer cars plus one from the B-main and top five after the feature will also cross the scales.

3C. Carburetors: One four-barrel carburetor only of any brand is allowed. The engine must be naturally aspirated through the hood of the car.

3C1. Carb spacers for 604 (must be flat on top and bottom) - 1" spacer maximum with a .040 tolerance

3C2. Carb spacers for 602 (must be flat on top and bottom) - 2" spacer maximum with a .040 tolerance

3C3. One gasket per surface .070 maximum.

3D. Transmission: Bert, Brinn, or Falcon type transmissions allowed. It must have a working clutch with forward and reverse gear. Drive shafts should be painted white with car number. This is a safety issue! Drive shaft loop is highly recommended. Air shifters not allowed. Carbon fiber, aluminum, or steel drive shafts permitted.

3E. Fuel: Drivers must claim the type of fuel they are using for a comparison test. E-85 must be plant-based E-85; NO METHANOAL. Drivers claiming pump E-85 should have a specific gravity of 85 +/- 3. Drivers who claim racing E-85 will be matched the specs of the manufacture. Drivers will be expected to present those specs.

3E1. Fuel and Motor Oil tests may be performed during post-race tech or sent to the labs for testing. Any suspicious fuel or motor oil will then be sampled, and lab tested. Additives that will be tested for but not limited to are nitromethane, propylene oxide, alcohol (all types), aldehydes, aminobiphenyl, benzene, borane, benzidine, beryllium compounds, bromine compounds, butadienes, chlorinated compounds, chromates, dioxane, MTBE, ethyl acrylate, ethylene oxide, hydrazine compounds, dioxane, methylenedianiline, naphthylamine, nitrogen compounds, styrenes, toluidine, and xylydine. Any of these compounds that are not included in fuel claimed or in correct amounts matching benchmarks will be deemed illegal.

3E2. Fuel protests cost \$150 and will be sent to the lab. Motor Oil protests cost \$200 and will be sent to the lab. See tire penalties below. The same penalties will apply to fuel found to be wrong.

3E3. Fuel Systems: Mechanical fuel pumps only. No electric fuel pumps of any type will be allowed. No nozzles, etc. may be connected to the fuel system at any point. Only one fuel system per car is permitted.

3E4. Exotic versions of E-85 are not allowed, for example, C85 from VP. If you are running a fuel that is outside of the standard options, please contact the series for approval at least 1 week before the event you wish to use the fuel in question.

3F. Evacuation Systems: Evacuation systems are not allowed. This means any type of vacuum system; includes vacuum from that of breather system and/or any other means of pressure evacuation from crankcase.

3G. Oil Pump/Pressure: Oil pumps must be as they come from the factory with the correct engine/oil pump combination (therefore the 602 Oil Pump is not legal on a 604). The original stock GM spring may not be altered from the factory with no additional shims. Wet sump only. No external oil pumps (even if considered "wet"). Remote oil filters and lines are permitted. One remote oil filter is allowed. One oil cooler is allowed. For a 604, anything over 48 lbs at 1800 rpm after qualifying may be subject to additional inspection. Lifters may not be altered in any manner and must be as they are from the factory.

3H. Distributor: Any electronic ignition is allowed except for the ones listed in 3H1. No crank trigger, no distributor-less multi-coil, no magneto systems, also no traction control devices are allowed.

3H1. The following ignition boxes will not be permitted for use: MSD Red 6 Box (Part No. 6530), MSD Black 6 Box (Part No. 65303), MSD Gold 7 Box (Part No. 7531), Fast Ignition (Part No. 307222), MSD Ultra 6A (Part No. 6202), MSD Ultra 6AL (Part No. 6423), Ultra 6AL Plus (6523), or any other box from any manufacture that has Bluetooth capabilities.

- 3I. Starter:** Cars must all have a starter that is in proper working order.
- 3J. Water Pumps:** Water pumps may be cast iron or aluminum. No electric water pumps or fans will be permitted.
- 3K. Headers:** Collector type headers are required. You must have four tubes into one collector. No merge collectors. No tri-y headers.
- 3L. Exhaust:** Mufflers are permitted but are not required unless the event is at a track where the track has a noise ordinance.
- 3M. Brakes:** All cars must have operational 4-wheel braking systems. An electric or manual proportioning valve is permitted. Carbon fiber, titanium, or other exotic materials are not legal. Brake rotors must be magnetic.
- 3N. Electronic Devices:** No electronic devices thereby enhancing adjustment of a car is allowed.
- 3N1. Traction control is NOT legal.
 - 3N2. Remote-control devices are not allowed at any time.
 - 3N3. No electronic devices controlling shocks are allowed.
 - 3N4. Exotic materials (titanium, carbon fiber, tungsten, etc.) are illegal.
 - 3N5. Carbon fiber drive shafts are legal (for safety purposes).
 - 3N6. No electronic devices that transmit voice or data are allowed at any time.
 - 3N7. Adjustable restrictor plates are not allowed.
 - 3N8. No data systems will be allowed. The same penalties that apply to tire infractions will apply here.
 - 3N9. No cell phones or any other electronic devices are allowed in the car or on the driver during any racing event. Driver may be inspected after the event during post-race technical inspection.
 - 3N10. Go Pros or other similar cameras will be the only type of electronic devices permitted at all on the car and this is only if it doesn't interfere with either the transponder or Raceiver.
 - 3N11. Raceivers: It is the driver's responsibility to have a working Raceiver. It is NOT THE RESPONSIBILITY of the series to make sure a driver has working batteries. If a driver's Raceiver is not working or he is not wearing it, he will be put off the track.
 - 3N12. Transponders: Any transponders owned by the driver are their own responsibility. If a driver forgets to attach his transponder or it malfunctions, he will not be scored. If a rental transponder from the series malfunctions, he will be scored/allowed to qualify again.
- 3O. Driver's Compartment Safety:** Window nets, gloves, fire suits, and helmets (with fire resistant interior) are required.
- 3O1. Seat belts cannot be more than two years old (There will be a 25-pound penalty if they are.).
 - 3O2. American Crate All-Star Series Strongly Urges the use of a Hans or Hutchinson (or similar) Device.
 - 3O3. Drivers must use a quick release steering wheel.
 - 3O4. Batteries cannot be in the driver's compartment and must have insulated cable ends or plastic covers to prevent fueling fires.
 - 3O5. Drivers must have either (1) a working fire suppression system or (2) a signed waiver with a working fire extinguisher. **THE ACAS STRONGLY ENCOURAGES THE USE OF A FIRE SUPPRESION SYSTEM.**

3O6. A master cut off switch, within reach of the driver, for the car is required.

3O7. A full containment seat is recommended, or an aluminum or carbon fiber seat with a bolt on head rest will be allowed.

3P. Wheels: Maximum 14” steel or aluminum wheels with bead locks are permitted. Carbon fiber or titanium is not legal.

3Q. Tires: Left Front: Open, **Right Front and Left Rear: Pro 2, Right Rear: Pro 2 or Pro 4.** Grooving and siping is permitted. No chemical alteration. Durometer will be spot checked and suspicious tires will be sampled. **There will be a two race burn off on the right front tire, any spec or block pattern tire may be run on the right front during that period.**

3Q1. Tires may be inspected at any time (numbers, specs, altering, etc.). All tires must have shoulder plates. Tires may be checked by independent lab for treating and other alterations. Tires not conforming to the manufacturer’s benchmark will be deemed illegal.

3Q2. ACAS reserves the right to alter tire rules for the standpoint of SAFETY AND LOCAL TIRE RULES. Softening, conditioning, and tires not conforming to manufacture’s benchmark are illegal. There are NO appeals and the lab results are FINAL.

3Q3. Protesting of the Tire is \$125 and must follow the same procedures as protesting an engine. Please see rule 3A9.

3Q4. (Penalties based on 365-day period from time of infraction.)

1st Offense: \$300.00 fine, loss of points, loss of prize money, and **50**-point deduction to year end points total.

2nd Offense: \$500.00 fine, loss of points, loss of prize money, and **50**-point deduction to year end points total.

3rd Offense: \$1000.00 fine, loss of points, loss of prize money, and suspension to be set at ACAS discretion.

3R. Springs: Only coil springs will be allowed. No pneumatic springs, hydraulic springs, or air springs will be allowed. A shock that produces more than 75lbs of rod force when compressed to the center of the shock mounts measurement at the car’s static ride height is considered a spring and is illegal.

3R1. Coil springs must be made from magnetic steel.

3R2. Stacked springs are allowed.

3R3. Progressive springs are allowed.

3R4. Spring preload adjustments for coil springs must be made using mechanical adjusting nuts on the shock body. No air dumps or hydraulics.

3R5. Other than spring damping by the shock absorber, pneumatic, hydraulic, or electrically controlled adjusting devices, (static or dynamic) that affect spring preload or race car heights will not be permitted; air dump devices are not allowed.

3R6. Spring rubbers are allowed.

3S. Bump Stops: Bump stops are permitted. Bump springs are permitted. No pneumatic or hydraulic bump stops will be permitted.

3T. Shocks: One shock is allowed per wheel (except on the left rear where two shocks will be allowed, one in front of the rear end and one behind the rear end). The shocks must be mounted vertical to the axel tube, not horizontal. Shocks, at any position on the race car including lift bar or torque arm shocks, must be made of magnetic steel or aluminum. Thru rod/**mid-piston** style shocks will not be allowed. **(This rule includes thru rod shocks whether the shaft is exposed or not exposed).** Remote reservoirs are allowed. Each shock may have a

maximum of **three** external adjustment mechanisms. The external reservoir can have **two** external adjustments. The adjuster mechanism cannot be hidden by the rod end. Any and all adjusters must be on the shock body, on the shock rod, or on the remote reservoir. NO cockpit adjustment is permitted.

3T1. NO remote adjustment of shocks is permitted, including electronic adjustment of any kind.

3T2. Shock absorbers cannot contain any internal spring that functions as a load bearing suspension spring, internal coil bump spring above or below the working piston, nor internal bump stop of any kind.

3T3. Shock covers are permitted, but they must be removed for tech inspections.

3T4. Shock Protest: Protesting of the Shock is \$200 per shock you wish to protest. You may choose the shock you are protesting. Any driver from top five in qualifying or the feature may protest any driver in front of them. Protest must be paid with cash in hand within five minutes of qualifying times being posted or within 5 minutes of the time post-race tech starts after the feature event. If shock is found to be legal the protested driver will receive \$100, and the series will retain \$100. Protested driver will remove the selected shock and tech officials and protesting driver will visually inspect the shock. If shock is illegal series will confiscate the shock until the fine is paid in full.

3T4a. (Shock Penalties based on 365-day period from time of infraction.)

1st Offense: \$1,000.00 fine, loss of points, loss of prize money, and 25-point deduction to year end points total.

2nd Offense: \$2,000.00 fine, loss of points, loss of prize money, and 50-point deduction to year end points total.

3rd Offense: \$5,000.00 fine, loss of points, loss of prize money, and suspension to be set at ACAS discretion.

3U. Rear Ends: Any standard quick-change rear end. No open type (sprint car) rear ends are allowed.

3U1. Rear suspension: Standard 4 bar or swing arm rear suspensions only. No spring rods allowed. One shock per wheel except left rear is allowed. Chain limiters are allowed.

3W. Transponder Mounting Instructions:

3W1. Attach the transponder pouch to the left front frame rail (as far forward, not on the bumper). (For G3 style transponders, install the pouch in the vertical position with the silver label of the transponder facing the left side of the car.)

3W2. Use a zip tie through each eyelet to secure the pouch to the frame rail.

3W3. Install the transponder into the pouch with the silver label facing the racing surface (the flashing LED's will be pointed towards the rear of the car).

3W4. Close and latch the pouch flap.

3X. Bodies:

3X1. Rear Deck height measured from ground to the top of the T-Bar is 40" Maximum with driver in car. Rear Deck Height will be measure prior to qualifying if it's off it may be fixed, but only the first lap of qualifying will count. It may also be measured prior to any heat/b-main/feature, if it's found high it may be fixed and driver will start the tail of the event. Bottom right front Bumper to ground Maximum 15" high. No fins or raised lips of any kind are permitted anywhere along the entire length of the car.

- 3X2. The maximum width for the quarter panels measured from outside to outside (including plastic) is eighty-two inches (82").
- 3X3. The door-to-door measurement must not exceed ninety inches (90") in width when measured at the bottom of the doors in the center of the car (including plastic).
- 3X4. See diagram below for remaining body rules.

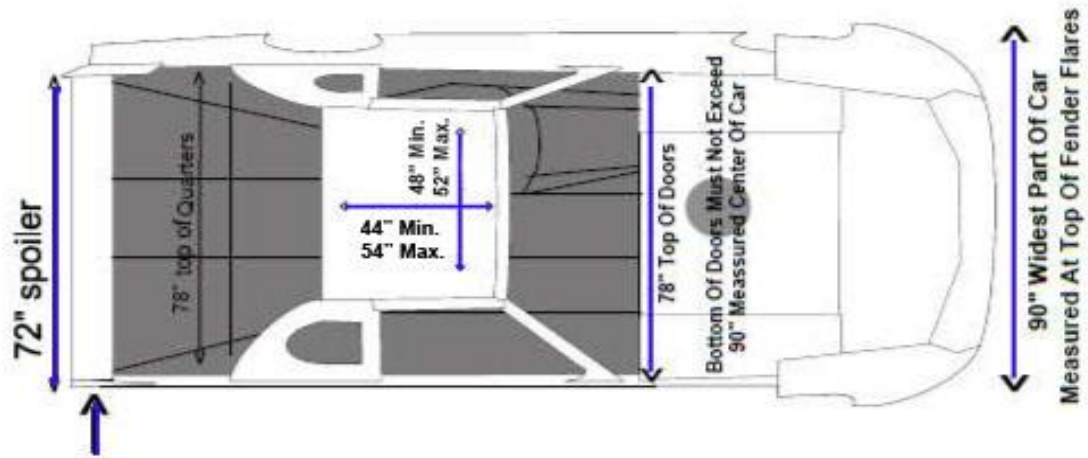

FRONT ROOF SUPPORTS 4" MAX. WITH 12" FLARE MAX. AT BOTTOM.
 REAR ROOF SUPPORTS OR "C" PILLARS WITH WINDOW OPENINGS
 ALLOWED BUT MUST BE SAME SIZE OPENING ON LEFT AND RIGHT SIDE,
 AND CANNOT BE OFFSET. CURVED OR ARCED ROOF SUPPORTS ALLOWED.
 3" MAX. ARC ALLOWED AT WIDEST POINT, CHECKED WITH STRAIGHT EDGE
 EXTENDED FROM ROOF EDGE TO DOOR EDGE.

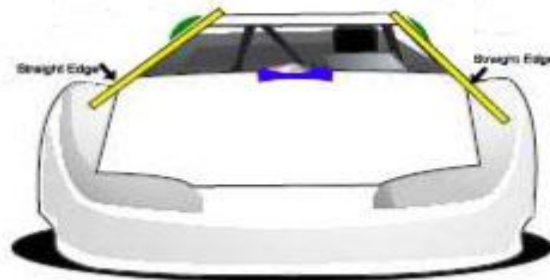
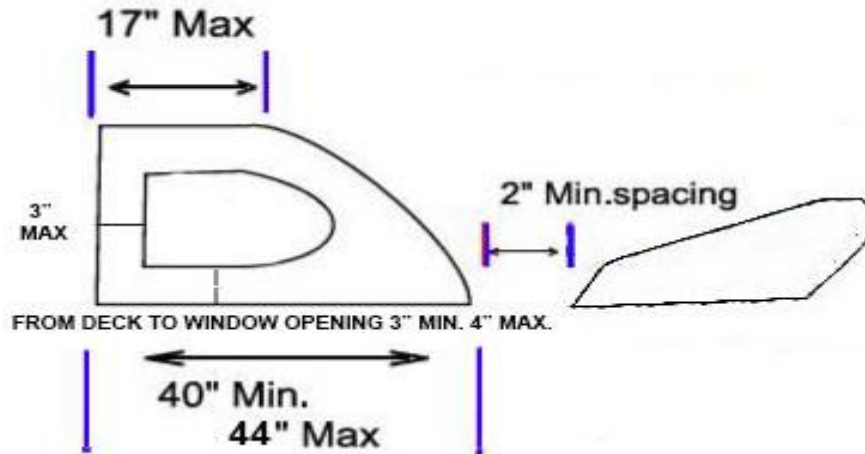

All body components 3" Min. above ground.
 All body measurements are maximum unless otherwise specified.

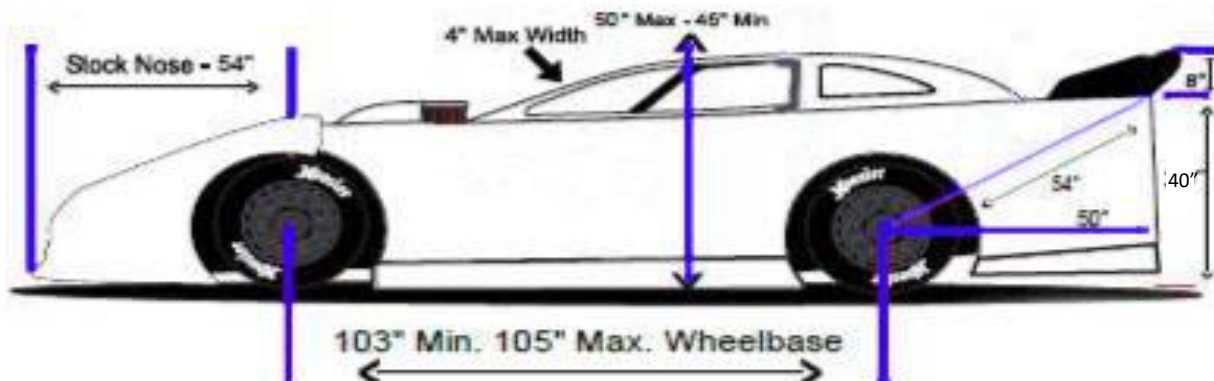

Rear deck height measured from ground to top of T-Bar is 40" with driver in car. The measurement of the spoiler is 8" from deck to top of spoiler.

REAR DECK HEIGHT MEASURED FROM GROUND TO TOP OF T-BAR IS 39" MAXIMUM WITH DRIVER IN CAR. THE MEASUREMENT OF THE SPOILER IS A TOTAL OF ALL MATERIAL INCLUDING ANY TURNS UP OR DOWN AND INCLUDES SUPPORT BRACE

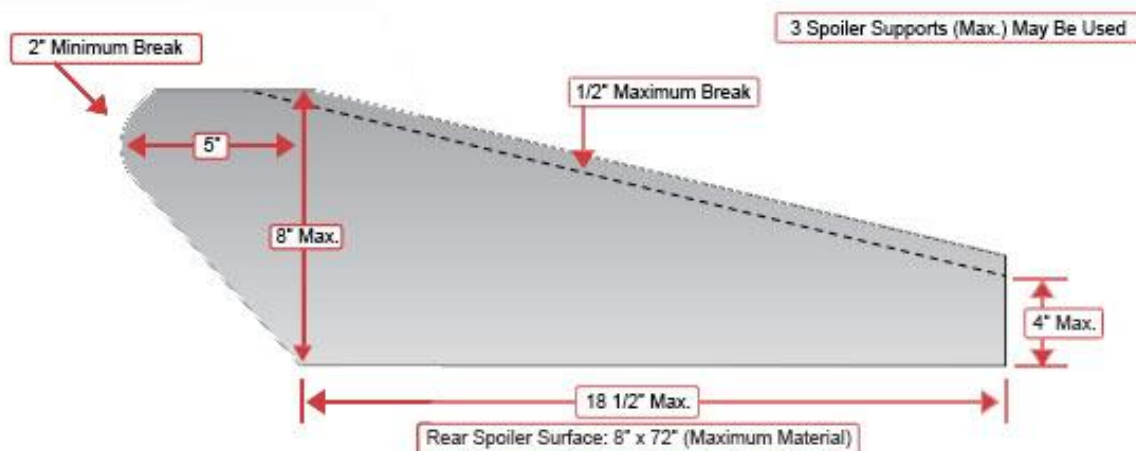

3X. Series Sponsor Decals: All cars competing in AAS events are expected to run series sponsor decals. Cars are subject to inspection for decals at any time. If car is found to not be running a series sponsor decal the payout for the car will be cut by 10%. *If track has already cut checks driver/car owner will be required to pay a fine for 10% of his/her payout before entering AAS Touring competition again.

Series Tech Staff Contact Information

Joe Rush
ACAS CEO
304-890-3827

info@americancrateallstarsseries.com

Ronnie Phillips
ACAS Technical Director
336-692-1999

Jesse Raynes
ACAS Technical Director
304-575-7294